

DE LA RUE
CASH SYSTEMS



DeLaRue

MACH 9



Euro
model

Coin sorter/counter

Fast, accurate coin processing for high volume applications



Available with
Coin Detection Euro
(CDE)

MACH 9

Coin sorter/counter



Fast, efficient & intelligent throughput

With a processing speed of up to 4500 coins per minute, the **MACH 9** is one of the fastest coin sorters/counters available in its class. The **MACH 9** is capable of sorting up to nine denominations of coin. With its large tilting inspection pan, holding up to 5000 coins, coupled with the unique auto-feed system, the **MACH 9** enhances productivity through efficient coin processing.

Ease of use

A graphic display provides clear function status and operational messages. Selectable bag stops, batch and grand totals are easily accessed via the direct keypad. Full travel keys enable easy and quick data entry.

Design

The **MACH 9's** ergonomic design is both functional and aesthetically pleasing, allowing the unit to fit into any work environment. With few moving parts and simplified electronics, the **MACH 9** is easy to maintain.

Coin Detection Euro (CD€)

With the addition of the Coin Detection Euro (CD€) option the **MACH 9** becomes the ideal machine to help manage the transition to the Euro.

De La Rue's Coin Signature Detection System (CSDS™) provides detection and rejection of counterfeit and foreign coins.

Multiple functionality

The **MACH 9** is easily adaptable to any high volume application. The Management Information Control System (MICS) option provides three levels of memory and allows other media – such as cheques, rolled coin and notes – to be entered, ensuring a comprehensive audit trail.

With four RS232 serial ports fitted as standard, the **MACH 9** can interface to other cash settlement systems and peripheral equipment such as currency counters, enabling complete cash reconciliation.

De La Rue Cash Systems Sorters/Counters are the direct result of over 100 years experience in designing, manufacturing and distribution of world-class coin processing machines. The quality management systems have been found to be in compliance with and registered to ISO-9002 standard. Worldwide service and support is provided through De La Rue Cash Systems network of branch offices and authorised distributors.

Technical Specification

Coin size range

Diameter: 15.5mm to 38.3mm

Thickness: 1.0mm to 3.0mm

Differential: 0.5mm minimum

Inspection pan capacity

Up to 5000 coins

Coin feeder capacity

Up to 10000 coins

Processing speed

Up to 4500 coins per minute

Sorting capability

Up to 9 different denominations

Bag stops

Fully adjustable

Security features

Lock out security to protect operating information

Battery back up in the event of power failure

Serial interface ports

Four RS232 ports as standard

Power supply

90V - 264V AC, 50/60 Hz

Options

High speed printer for audit trail

Remote display

Security doors

Coin sorter data conversion manager

Currency counter interface

Magnet kit

MICS control - includes:

3 levels of totals with programmable ID numbers, user programmable bag stops, media register for positive and negative inputs and up to 200 separate identifiers for teller/product totals.

Coin Detection Euro (CD€) for fast detection and rejection of foreign or counterfeit coins
Coin detection speed 3000 coins per minute

Dimensions

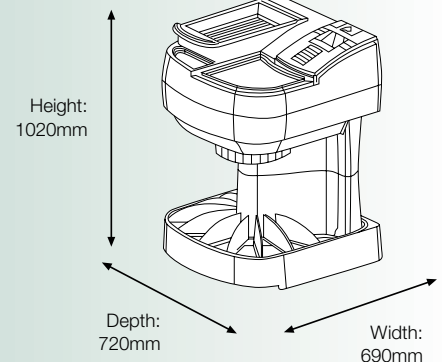

Weight: 90kg



This leaflet is for general guidance only. De La Rue International Limited is pleased to give detailed specifications of its products in this leaflet. As the company's products and services are continually being developed it is important for customers to check that the information contained herein includes the latest particulars. This document is not part of a contract or licence save insofar as may be expressly agreed.



© De La Rue International Limited 2001

DE LA RUE CASH SYSTEMS

De La Rue House
Jays Close
Viables
Basingstoke
RG22 4BS
www.delarue.com

