

DE LA RUE  
CASH SYSTEMS



DeLaRue

# MACH 12



Euro  
model

## Coin sorter/counter

Fast, heavy duty, accurate coin processing for high volume applications



Heavy Duty Option  
available

# MACH 12

## Coin sorter/counter



The **MACH 12** is a fast, accurate, high speed coin sorter, equipped with heavy duty components, making it the perfect choice for large volume coin processing applications.

### Fast, efficient throughput.

With a processing speed of up to 6000 coins per minute, the **MACH 12** is one of the fastest coin sorters/counters available. The **MACH 12** is capable of sorting up to nine denominations of coin/tokens.

### Ease of use

An easy to read, blue backlit graphic display provides clear function status and operational messages. Selectable bag stops, batch and grand totals are easily accessed via the direct keypad. Full travel keys provide for easy and quick data entry.

### Design

The **MACH 12's** ergonomic design is both functional and aesthetically pleasing, allowing the unit to fit into any work environment. With few moving parts, and simplified electronics, the **MACH 12** is easy to maintain.

### Multiple functionality

The **MACH 12** is easily adaptable to any high volume application.

The Management Information Control System (MICS) option provides three levels of memory and allows other media – such as cheques, rolled coin and notes – to be entered, ensuring a comprehensive audit trail.

With four RS232 serial ports fitted as standard, the **MACH 12** can interface to other cash settlement systems and peripheral equipment such as currency counters, enabling complete cash reconciliation.

### Extra Heavy Duty Applications

For those processing large volumes of coins the **MACH 12HD** adds an extra large inspection pan holding up to 10000 coins, enhanced life sorter plate and hard disk plug, and under hood lighting.

De La Rue Cash Systems Sorters/Counters are the direct result of over 100 years experience in designing, manufacturing and distribution of world-class coin processing machines. The quality management systems have been found to be in compliance with and registered to ISO-9002 standard. Worldwide service and support is provided through De La Rue Cash Systems network of branch offices and authorised distributors.

## Technical Specification

### Coin size range

Diameter: 15.5mm to 38.3 mm

Thickness: 1.0mm to 3.0mm

Differential: 0.5mm minimum

### Inspection pan capacity

Up to 5000 coins

### Coin feeder capacity

Up to 10000 coins

### Processing speed

Up to 6000 coins per minute

### Sorting capability

Up to 9 different denominations

### Bag stops

Fully adjustable

### Security features

Lock out security to protect operating information

Battery back up in the event of power failure

### Serial interface ports

Four RS232 ports as standard

### Power supply

90V - 264V AC, 50/60 Hz

### Options

High speed thermal printer for audit trail

Remote display

Dual bagging

Coin sorter data conversion manager

Currency counter interface

Magnet kit

Security doors

MICS control - includes:

3 levels of totals with programmable ID numbers, user programmable bag stops, media register for positive and negative inputs and up to 200 separate identifiers for teller/product totals.

### MACH 12HD

Heavy Duty - includes:

Extra large inspection pan

Under hood lighting

Enhanced life sorter plate and hard disk plug

### Dimensions

Height:  
1020mm

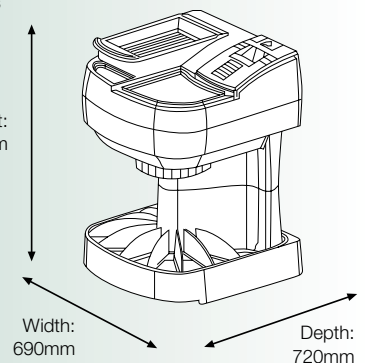

Width:  
690mm

Depth:  
720mm

Weight: 90kg



This leaflet is for general guidance only. De La Rue International Limited is pleased to give detailed specifications of its products in this leaflet. As the company's products and services are continually being developed, it is important for customers to check that the information contained herein includes the latest particulars. This document is not part of a contract or licence save insofar as may be expressly agreed.



© De La Rue International Limited 2001

### DE LA RUE CASH SYSTEMS

De La Rue House  
Jays Close  
Viables  
Basingstoke  
RG22 4BS  
www.delarue.com



DeLaRue