

**DE LA RUE
CASH SYSTEMS**



DeLaRue

CDS1000

Cash Deposit System

A secure, accurate and reliable cash deposit machine



CDS1000

Cash Deposit System



The **CDS1000** is a secure, accurate and reliable cash deposit machine, with the benefit of being compatible with all existing De La Rue **CDS 500** installations.

Secure audit trail

The **CDS1000**'s ID validation system matches the driver, operator, supervisor and engineer ID with a secure database, preventing unauthorised access. Each is then allowed access only to the relevant higher level functions. Unique transaction numbers, coin vault and note cassette ID's and configurable 'daily' and 'grand' totals, enable complete operation interrogation. The solution is further enhanced when interfaced with the De La Rue CADIS (Cash Deposit Interface System) software product.

Ease of cleaning

A slide out coin mechanism, integral inspection pan and removable dust tray, enables the operator to easily maintain the **CDS1000** for optimum performance.

Physical security

The high capacity note cassette and coin vault both feature auto-locks. The innovative cabinet design separates access to cash holding areas for security, the coin mechanism for cleaning and the printer for roll replenishment.

Accurate, efficient depositing

The **CDS1000** is designed to accept coin, note and 'other value' deposits of bus and coach drivers. The highly accurate counting and validating mechanisms ensure that transactions are dealt with quickly. Driver, operator and supervisor can be confident of complete accuracy between 'expected total' from the ticket revenue system and physical deposits.

User friendly

The **CDS1000** user interface enables the machine to be operated with the minimum number of interventions and prompting, allowing greater productivity in the transaction cycle.

Ease of cash handling

For ease of emptying, the coin vault has a sloping floor to reduce manual handling in the cash room. The modern note stacker and cassette system greatly reduces sorting and reconciliation time, further reducing operating costs.

De La Rue Cash Systems' coin sorters/counters are the direct result of over 100 years' experience in design, manufacture and distribution of world class coin processing machines. Worldwide service and support specialists are provided through De La Rue Cash Systems' network of branch offices and authorised distributors.

Technical Specification

Vault capacity

Up to 40,000 coins approximately

'1000' or '2000' note cassette options

Envelope slot in cabinet

(Vault and cassette full warning given)

Processing speed

>600 coins per minute

Approximately 1 note every 3 seconds

Up to 97% note acceptance rate

Security features

'One piece' cabinet design with anti-scuff coating

Auto-locks on coin vault and note cassette

Multi-level ID validation system

1300 transaction memory

Power supply

Convertible for most world-wide voltages and frequencies: 100V-240V AC, 50/60 Hz

Power

200W

Sound level

<70 dB

Note validator

Escrow/reject coin tray

Steel, removable

Printer

"Longlife" Thermal type with guillotine

Screen

Multi-line back-lit VGA

Keyboard

Steel, ATM style

Options

Swipe card reader

'2000' note cassette

Note escrow

Accessories

Coin vault, note cassette and reject tray

Dimensions

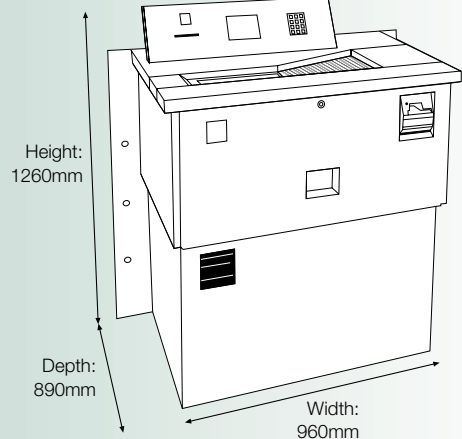

Weight: 256kg



This leaflet is for general guidance only. De La Rue International Limited is pleased to give detailed specifications of its products and services are continually being developed it is important for customers to check that the information contained herein includes the latest particulars. This document is not part of a contract or licence save insofar as may be expressly agreed.



© De La Rue International Limited 2000

DE LA RUE CASH SYSTEMS

De La Rue House
Jays Close
Viables
Basingstoke
RG22 4BS
www.delarue.com



DeLaRue